

NTF-25

MAIN FEATURES

- Tray forming up to 25 trays per minute
- 2-axis servo motion: glue application (or transfer), and forming head motion
- Active tray magazine, reload on the fly
- Flexible forming funnel design, accommodates material variance/imperfections
- Tool-less changeover - generally less than 5 minutes
- Smallest industry footprint
- Stainless steel frame STANDARD
- Washdown available

NTF-25 SERVO TRAY FORMER

• Compact • Ergonomic • Intelligent

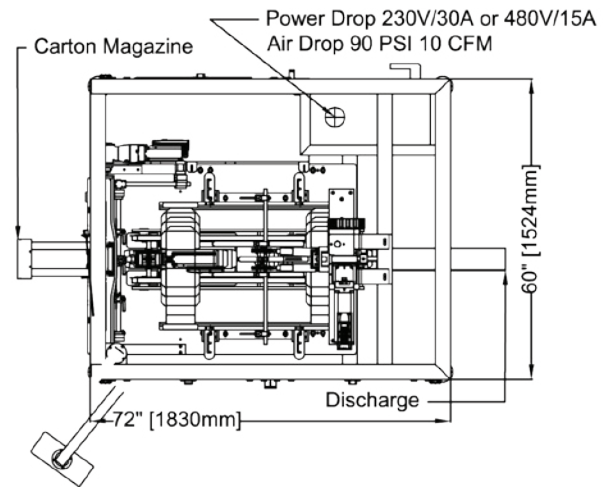
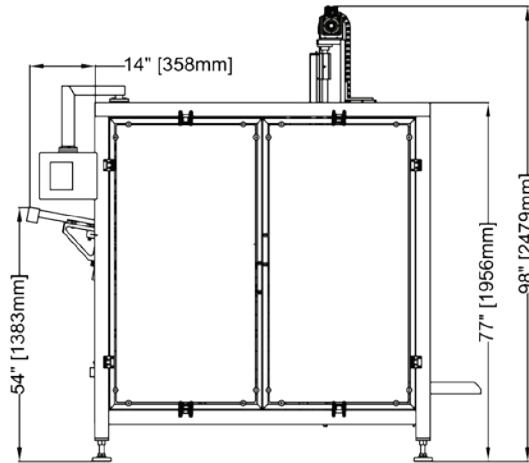

SPECIFICATIONS:

DRIVE:	Servo-driven
SPEED:	Up to 25 trays per minute single head
PRODUCT SIZE RANGE:	Per Project Specification
TRAY SIZE RANGE:	Per Project Specification
BLANK FEED:	Positively placing tray blanks into servo driven flights. Pneumatic Tray Feeder with vacuum to remove tray blanks from the magazine (servo optional)
WEIGHT:	Approximately 500kg.
MAGAZINE CAPACITY:	1 ft. (~700 blanks)
FRAME:	Stainless Steel construction
GUARDING:	Anodized Aluminum/ stainless steel and fully accessible polycarbonate interlocked guarding with adjustable feet or casters
FINISH:	All parts in contact with product are stainless steel, anodized aluminum or plastic
CONTROLS:	Bosch Rexroth, Omron, Allen Bradley, with Touch screen HMI
INSTALLATION REQUIREMENTS:	Power: 240 VAC/30 Amps. 3 phase, 50/60 Hz Air: 90 PSI, 10 cfm



400 Steeprock Drive, Toronto
Ontario, Canada, M3J 2X1
Tel: (416) 663 7071
www.nuspark.com

Distributed by