



VRC-60

MAIN FEATURES

- Accommodates up to 12 operational stations
- Up to 60 cartons per minute
- Allows for manual or automatic loading
- Delicate carton handling via vacuum nest
- Ergonomic Design
- Smallest Industry Footprint
- Stainless Steel Frame STANDARD

VRC-60 VERTICAL ROTARY CARTONER

"Smallest cartoner in the industry"

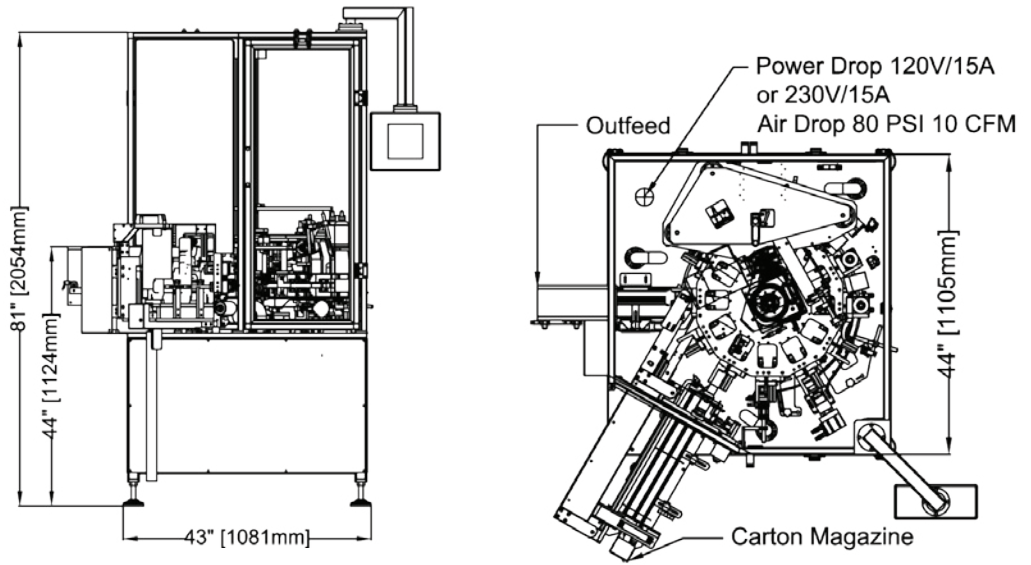

SPECIFICATIONS:

DRIVE:	12 positions indexer driven by AC motor, VFD controlled
SPEED:	Up to 60 cartons per minute
PRODUCT SIZE RANGE:	Per Project Specification
CARTON SIZE RANGE:	Length: min - ½" (13mm) max - 5" (127mm) Width: min - ½" (13mm) max - 4" (101mm) Height: min - 2" (50mm) max - 15" (380mm)
CARTON FEED:	Positively erecting cartons into buckets, holding them in place by integrated suction cups. Carton feeder mechanically linked with crankshaft mechanism
MODE:	- Rotary intermittent motion - 12 operating stations allowing, direct or field installation of options including: <ul style="list-style-type: none"> • Leaflet insertion • Printer • Barcode reader • Open flap detection • Missing product detection • Automatic reject - High speed in-feed systems are designed to meet specific product loading - Hot melt system or fold and tuck (airplane or reverse)
WEIGHT:	Approximately 350 kg / 770 lbs.
MAGAZINE CAPACITY:	up to 700 cartons
FRAME:	Complete Stainless Steel Construction
CONSTRUCTION:	Anodized Aluminum/ stainless steel and fully accessible polycarbonate interlocked guarding with adjustable feet or optional casters
CONTROLS:	Bosch Rexroth, Omron, Allen Bradley with touch screen HMI
INSTALLATION REQUIREMENTS:	Power: 120 VAC with 1 phase or 240 VAC with 3 phase @ 15 amps. Air: 90 PSI, 10 cfm
VALIDATION (Optional):	Open flaps inspection, barcode scanners, product present verification, and reject station



400 Steeprock Drive, Toronto
Ontario, Canada, M3J 2X1
Tel: (416) 663 7071
www.nuspark.com

Distributed by

