



## NTL-50

### MAIN FEATURES

- DELTA Style 2 axis robot - maintenance free design
- Top load up to 50 picks per minute
- Heavy Payload capability, up to 100lbs
- Tool-less changeover - under 10 minutes
- Economic footprint
- Stainless Steel Frame STANDARD
- Washdown Available

# NTL-50

## ROBOTIC TOP LOADER

• Compact • Adaptable • Dependable

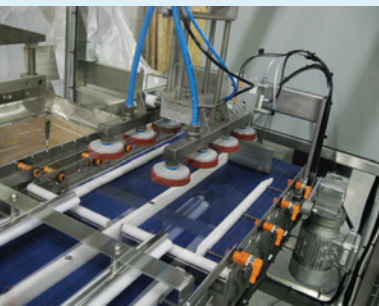
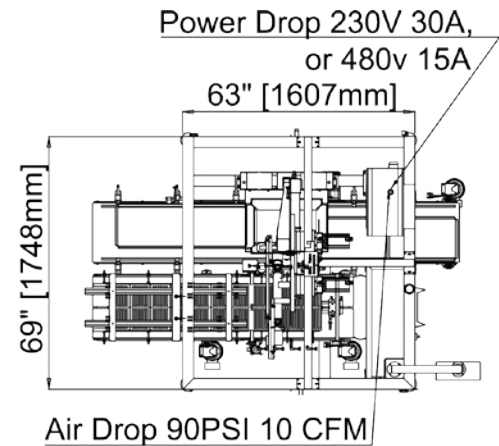
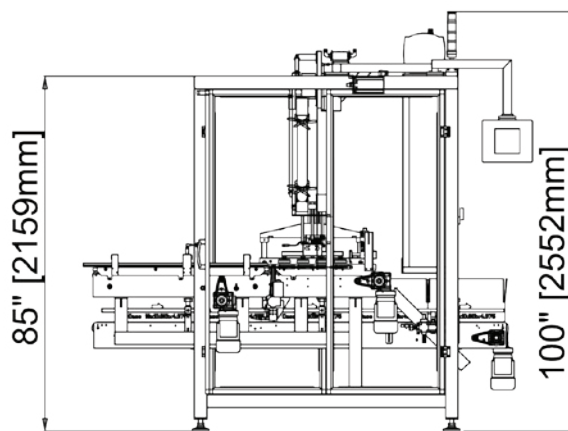

### SPECIFICATIONS:

DRIVE: AC Motors (Case and product transfer), Servo Drives ("Delta" Loader)

SPEED: Up to 50 picks per minute

PRODUCT SIZE RANGE: Per Project Specification, maximum envelope 24" (L) x 16" (W)

CASE SIZE RANGE: Length: max - 24" (610mm)  
Width: max - 16" (406mm)  
Height: max - 16" (406mm)

ADJUSTMENTS: Quick Changeover with available Hand-wheel size adjustments throughout

FRAME: Stainless Steel construction

CONSTRUCTION: Full length polycarbonate with extruded anodized aluminum frames  
guarding interlocked with door safety switches.

FINISH: Powder coat epoxy. All parts in contact with product are stainless steel,  
anodized aluminum or plastic

ELECTRICAL: Schneider Electric, Allen Bradley, Omron  
Touch screen HMI  
NEMA 12 wiring and enclosures  
3-Color stackable warning lights

PNEUMATICS: "FESTO"

INSTALLATION REQUIREMENTS: Power: Voltage 230 VAC/30 Amps. or 480 VAC/15 Amps.  
3 phase, 50/60 Hz. Control voltage: 24VDC. Air: 90 PSI at 10 cfm



1111 Flint Road, Unit 29, Toronto  
Ontario, Canada, M3J 3C7  
Tel: (416) 663 7071  
www.nuspark.com

**Distributed by**